

INSTALLATION INSTRUCTIONS

PRO-SHIFT LITE

MODEL 5340 For Standard and Electronic Racing Ignitions,
5341 For Vertex OAC Ignitions,
5342 For Vertex OXC and Super Mag. Ignitions



Features

- High accuracy—Custom RPM Modules (Pills).
- Order separately in different RPM ranges with 5 modules per pack at 200 rpm intervals.
- Easy to select 4, 6, and 8 cylinder operation.
- Special amber lens assures you won't miss the lite.
- Easy change wedge-base bulb (G.E. #921 Bulb).
- User choice of dash or tach mounting.
- Self-test feature flashes lamp when power is turned on.

Module Kits

Each kit includes 5 calibrated module "pills" in 200 RPM increments beginning with the first number listed.

Example:

5357 7,000 (7.0, 7.2, 7.4, 7.6, 7.8 x 1000) or;
5367 6,600 (6.6, 6.8, 7.0, 7.2, 7.4 x 1000)

5353 3,000	5360 10,000	5367 6,600
5354 4,000	5361 11,000	5368 7,600
5355 5,000	5362 12,000	5369 8,600
5356 6,000	5363 13,000	5370 9,600
5357 7,000	5364 3,600	5371 10,600
5358 8,000	5365 4,600	5372 11,600
5359 9,000	5366 5,600	5373 12,600

Cylinder Select

Place switch in desired cylinder range.

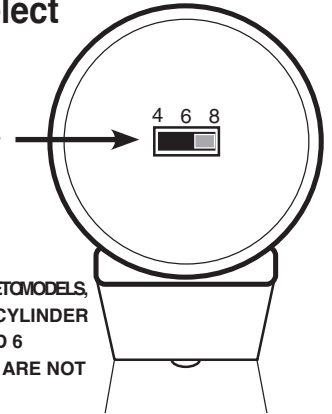

NOTE: MAGNETO MODELS, OPERATE IN THE 8 CYLINDER RANGE ONLY. 4 AND 6 CYLINDER MODELS ARE NOT AVAILABLE.

Wiring

Standard Ignition

Model 5340

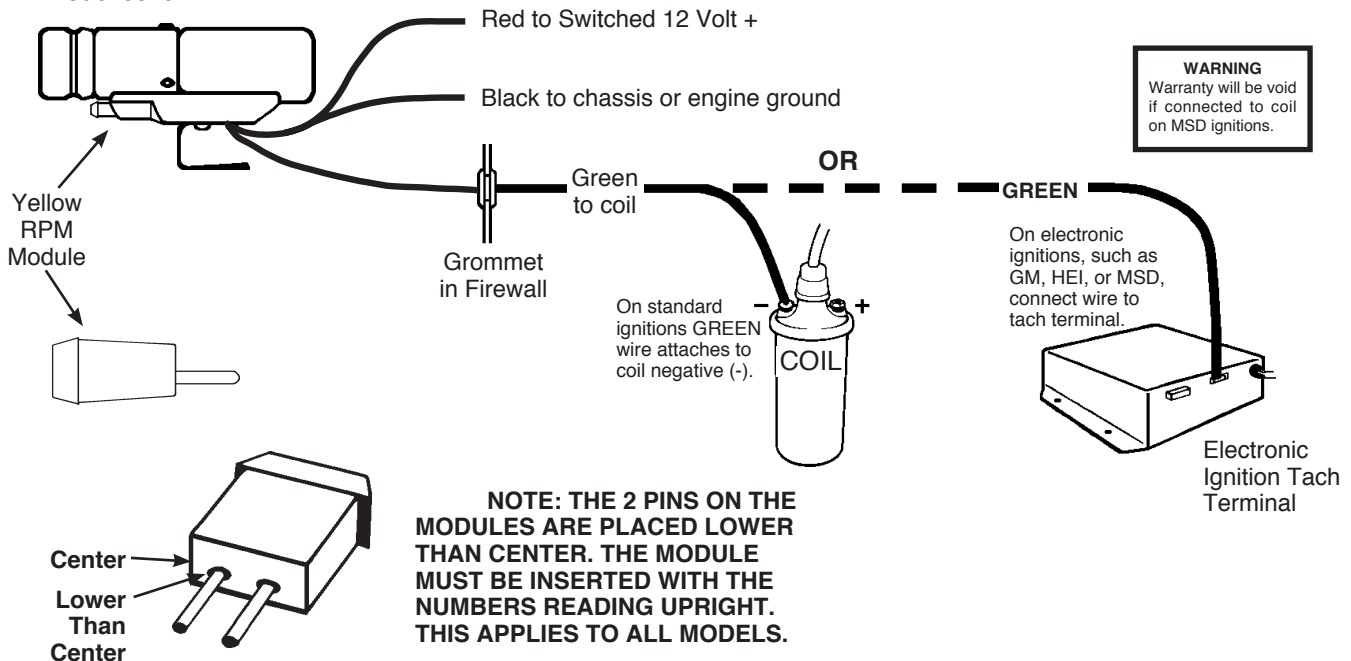

Vertex OAC

Model 5341

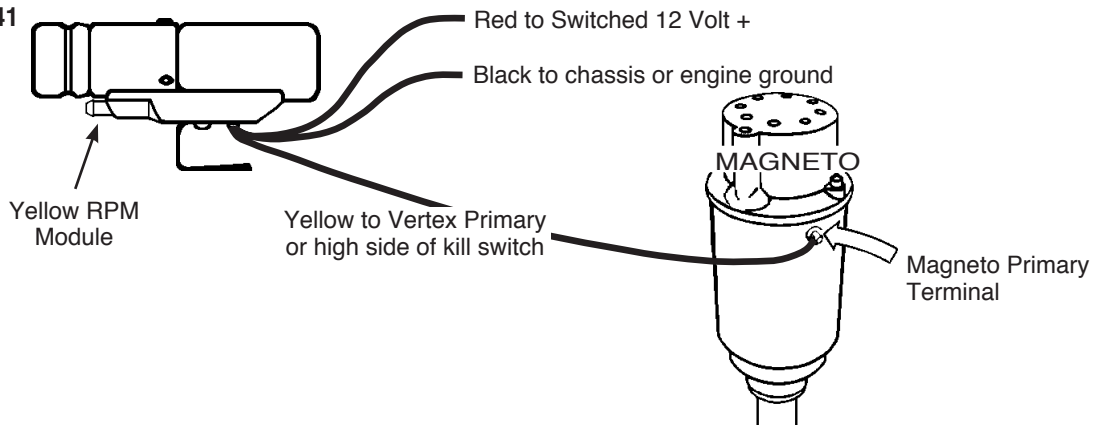

Super Mag and Vertex OXC

Model 5342

Tip: For Super Mag applications it is recommended that ground straps be connected from the magneto clamp to both cylinder heads.

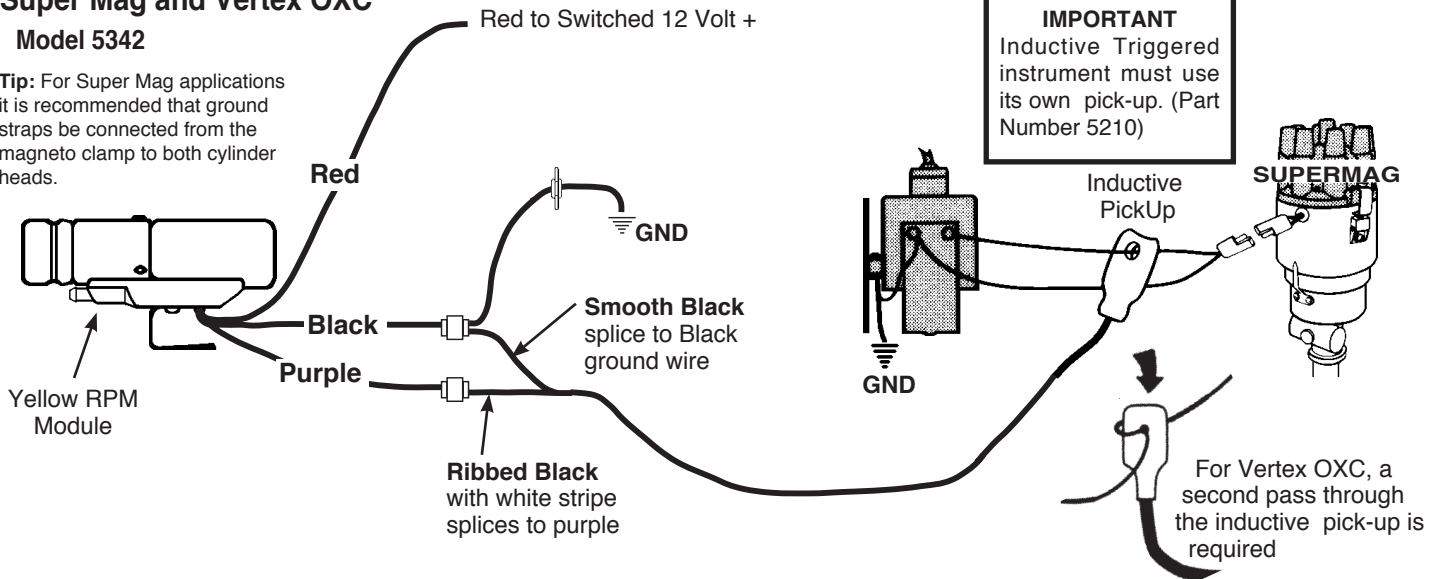

Mounting

On Your Auto Meter Tachometer

It is not necessary to remove the base from the Pro-Shift to accomplish proper mounting. For tach mounting, loosen the shock strap, slip the base under the inner strap and re-tighten the strap assembly.



On top of Your Dash

On Dash use screws to fasten base to dash.

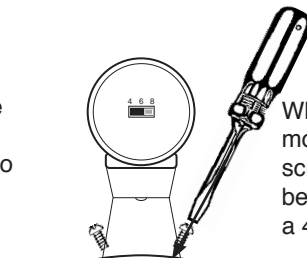

When dash mounting, screws should be driven in at a 45° angle.

BACK VIEW

Initial Testing

1. Set cylinder select switch on back of light tube to 4 cylinder for pre-race mode.
2. Insert an RPM module (low PRM test module as described below).
3. Turn power on. Lamp should turn on briefly. This will not happen without a module inserted in product.
4. Start engine and free rev to the module RPM. Include with the PRO SHIFT is a low RPM pill module for testing. Insert pill module and rev engine to appropriate RPM. This will allow you to check the light to be certain that it works and can also be used at any time as a "Test Pill" to check out the system. Lamp will turn on, and stay on, at and above the set RPM. In the 4 cylinder test mode, 8 cylinder cars will light at 1/2 the shift RPM and 6 cylinder cars will light at 2/3 the shift RPM.

Troubleshooting

1. Do you have 12 volt power?
2. Double check your ground.
3. Is the module inserted into the receptacle?
4. Is your inductive pickup installed correctly (5352 only).
5. If you have checked the above and are still having difficulty, call Auto Meter customer service at (815) 895-8141

LED Conversion Kit

Your PRO SHIFT can be converted to LED's using model 5339 Conversion Kit. This kit changes your PRO SHIFT FROM an incandescent bulb to a fast reacting set of 4 large super bright LED's.

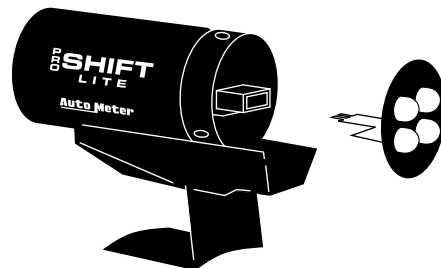

Note: On 4 cylinder applications light may flicker at low RPM.

SERVICE

For service send your product to Auto Meter in a well packed shipping carton. Please include a note explaining what the problem is along with your phone number. Please specify when you need the product back. If you need it back immediately mark the outside of the box "RUSH REPAIR," and Auto Meter will service product within two days after receiving it. (\$10.00 charge will be added to the cost of "RUSH REPAIR.") If you are sending product back for Warranty adjustment, you must include a copy (or original) of your sales receipt from the place of purchase.

12 MONTH LIMITED WARRANTY

Auto Meter Products, Inc. warrants to the consumer that all Auto Meter High Performance products will be free from defects in material and workmanship for a period of twelve (12) months from date of the original purchase. Products that fail within this 12 month warranty period will be repaired or replaced at Auto Meter's option to the consumer, when it is determined by Auto Meter Products, Inc. that the product failed due to defects in material or workmanship. This warranty is limited to the repair or replacement of parts in the Auto Meter instruments. In no event shall this warranty exceed the original purchase price of the Auto Meter instruments nor shall Auto Meter Products, Inc. be responsible for special, incidental or consequential damages or costs incurred due to the failure of this product. Warranty claims to Auto Meter must be transportation prepaid and accompanied with dated proof of purchase. This warranty applies only to the original purchaser of product and is non-transferable. All implied warranties shall be limited in duration to the said 12 month warranty period. Breaking the instrument seal, improper use or installation, accident, water damage, abuse, unauthorized repairs or alterations voids this warranty. Auto Meter Products, Inc. disclaims any liability for consequential damages due to breach of any written or implied warranty on all products manufactured by Auto Meter.

FOR SERVICE SEND TO: **AUTO METER PRODUCTS, INC.** 413 W. Elm St., Sycamore, IL 60178 USA (815) 899-0801

Email us at autometer@autometer.com