

Flow Chart Programming Instructions for : Speedometer 2" Controller

START HERE

PROGRAM MAIN MENU

(Press one button at a time)

MAIN MENU



NORMAL/DIAL BRIGHTNESS
Press down and up buttons to adjust dial brightness. Press the center button to save and advance to **PEAK PLAYBACK**.



NORMAL/DIAL BRIGHTNESS
ON POWER UP THE GAUGE READS THE **SENSOR MPH**. Press the center button to advance to **PEAK PLAYBACK**. OR
OPTION:LEARN SPEED BY MILE POSTS



PEAK PLAYBACK
Pointer will now display peak playback. The peak value is constantly monitored and the gauge updated every 15 seconds. Press the center button to advance to **HIGH RED-LINE SETTING**.



PEAK PLAYBACK
Press the center button to advance to **HIGH RED-LINE SETTING**. OR
OPTION:RESTORE FACTORY DEFAULT



HIGH RED-LINE SETTING
Press down and up buttons to move dial pointer to the high threshold. Press the center button to save and advance to **LOW THRESHOLD SETTING**.



HIGH RED-LINE SETTING
Press the center button to advance to **LOW THRESHOLD SETTING**.
OPTION: CALIBRATE GAUGE BY SPEED



LOW THRESHOLD SETTING
Press down and up buttons to move pointer to low threshold. Press the center button to save and advance to **COLOR SCHEME**.



LOW THRESHOLD SETTING
Press the center button to advance to **COLOR SCHEME**.



COLOR SCHEME
Press down and up buttons to select a color scheme. (OFF-VIOLET-BLUE-GREEN-YELLOW-ORANGE-RED-WHITE). Press the center button to save and advance to **DIAL BRIGHTNESS**



COLOR SCHEME
Press the center button to advance to **NORMAL/DIAL BRIGHTNESS**. OR
OPTION: DEMO MODE



DIAL BRIGHTNESS
Press the RIGHT or LEFT command button to control the brightness of the faceplate illumination. Press the center button to save and advance to **NORMAL OPERATION**



DIAL BRIGHTNESS
Press the center button to advance to **NORMAL OPERATION**
OPTION: ADJUST POINTER BRIGHTNESS

- **CAUTION:** FOLLOW WIRING INSTRUCTION CAREFULLY. INCORRECT RELAY WIRING WILL LEAD TO PREMATURE NITROUS OXIDE ACTIVATION.
- **WARNING:** INSTALLATION MUST BE PERFORMED BY AN EXPERIENCED TECHNICIAN. SYSTEM MUST BE INSTALLED ACCORDING TO MANUFACTURER RECOMMENDATIONS.
- DISCONNECT THE NEGATIVE BATTERY TERMINAL BEFORE INSTALLATION.
- USE CARE WHEN CONNECTING OR DISCONNECTING THE WIRING HARNESS. PULL OUT EACH CONNECTOR WHILE PRESSING THE LOCK OF THE CONNECTOR FIRMLY.
- NEVER DISASSEMBLE, MODIFY OR TAMPER WITH THE UNIT.
- PROPARTS,LLC IS NOT RESPONSIBLE FOR INCORRECT TURBOCHARGER SIZING, EXCESSIVE EXHAUST PRESSURE, OR INADEQUATE WASTEGATE

- OPERATION.
- THIS UNIT IS DESIGNED ONLY FOR DC 12V TYPE VEHICLES WITH NEGATIVE GROUND.
- CHECK THE AIR/FUEL RATIO ONCE THE BOOST PRESSURE IS SET TO PROTECT AGAINST LEAN FUEL SUPPLY THAT COULD CAUSE ENGINE DAMAGE.
- DO NOT USE BOOST CONTROL IN CONJUNCTION WITH ANY TYPE OF "DRAW THROUGH" FUEL SYSTEM.
- DO NOT ADJUST THE UNIT WHILE DRIVING.
- DO NOT USE THIS UNIT UNDER EXTREMELY HOT OR COLD CONDITIONS.
- DISCONTINUE USE OF THIS PRODUCT IF THE GAUGE DOES NOT OPERATE OR A STRANGE ODOR OR SMOKE IS PRESENT.

Flow Chart Programming Instructions for : Speedometer 2" Controller

SUBMENU (ENTER FROM MAIN MENU)

(Press two(2) buttons simultaneously for 5 seconds)

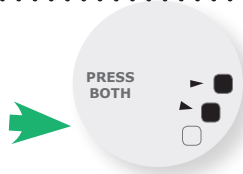

OPTION: LEARN SPEED BY MILEPOSTS:
THE DEFAULT SIGNAL IS 1000 PULSES PER MILE AT 60 MPH. ANY CHANGES REQUIRE A LEARNING SETUP. PROCEED TO A RACE SHOP EQUIPPED WITH A DYNAMOMETER OR A RACE TRACK. PRESS THE CENTER AND RIGHT BUTTONS FOR 5 SECONDS. THE FACE PLATE WILL FLASH BLUE. DRIVE THE MEASURED MILE AT 30 TO 60 MPH. PRESS THE CENTER BUTTON AS YOU PASS THE START OF THE MILE AND PRESS AGAIN AS YOU PASS THE END OF THE MILE FOR ONE SECOND THE DIAL WILL FLASH RED WHILE YOU DRIVE THE MILE. CALIBRATION IS COMPLETE.

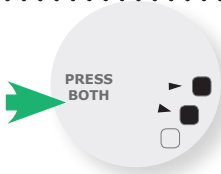
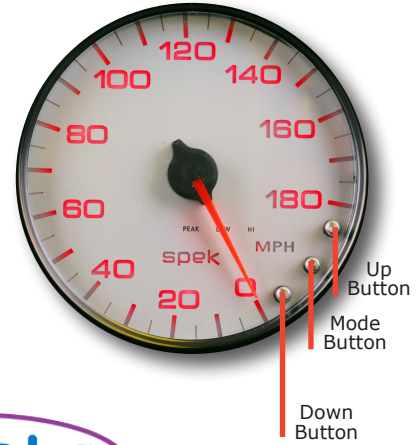

OPTION: RESTORE FACTORY DEFAULT
While in **PEAK PLAYBACK**, press and hold the center and right buttons for five seconds. Dial pointer will step five times and return to zero. This will erase all user-programmed calibrations and settings, and return to **NORMAL/DIAL BRIGHTNESS**.

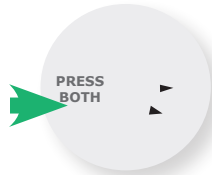

OPTION: CALIBRATE GAUGE BY SPEED: THE DEFAULT SIGNAL IS 1000 PULSES PER MILE AT 60 MPH. ANY CHANGES REQUIRE A LEARNING SETUP. PROCEED TO A RACE SHOP EQUIPPED WITH A DYNAMOMETER OR A RACE TRACK. ON A RACE TRACK HAVE A FRIEND DRIVE A PACE CAR AT 60 MPH. HAVE ANOTHER PERSON IN THE CAR TO PRESS THE CONTROL BUTTONS ON THE GAUGE. PRESS THE CENTER BUTTON TWICE UNTIL THE RED "HI" LED IS LIT. THIS IS THE HIGH THRESHOLD MODE. PRESS THE CENTER AND RIGHT BUTTONS FOR 5 SECONDS. THE FACE PLATE WILL FLASH GREEN. CAREFULLY MATCH THE SPEED OF THE PACE CAR AND PRESS THE CENTER BUTTON AT 60 MPH TO RECORD THE CALIBRATION. (NOTICE THAT THIS METHOD DEPENDS ON THE ACCURACY OF THE PACE CAR'S SPEEDOMETER)

PROGRAM SUBMENU

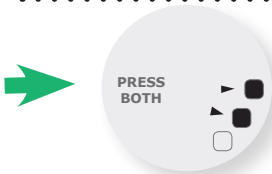

OPTION: DEMO MODE
WHILE IN **COLOR SCHEME**, press and hold the center and right buttons for five seconds. Dial will scroll through the seven color schemes. The **HI**, **LOW** and **PEAK** will light, and the dial pointer will move.



OPTION: DEMO MODE
Press the center button to return to **NORMAL/DIAL BRIGHTNESS**.

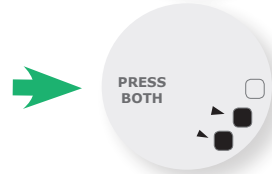

OPTION: POINTER BRIGHTNESS
While in **DIAL BRIGHTNESS**, press and hold the center and left buttons for five seconds to enter pointer brightness mode. The dial pointer will start to flash and point to the upper right.

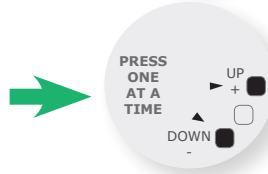

OPTION: POINTER BRIGHTNESS
Press down and up buttons to adjust the pointer brightness. Press the center button to save and return to **NORMAL/DIAL BRIGHTNESS**.

ProParts, LLC Limited Warranty: ProParts, LLC warrants all merchandise against defects in factory workmanship and material for 12 months from the original purchase date. Proof of purchase is required; otherwise the warranty period shall default to 12 months from date of manufacture as indicated by the date code on the product. This warranty applies to the first retail purchaser and covers only those products exposed to normal use or service. This warranty excludes items used for purpose to which it is not designed, or which has been altered in any way that would be detrimental to the performance or life of the product by misapplication, misuse, negligence or accident. When it is determined by ProParts, LLC after examination that a product is defective, ProParts, LLC will repair, replace or issue credit for that product through the original selling dealer or by direct basis. In no event shall this warranty exceed the original price of the product. ProParts, LLC assumes no responsibility for diagnosis, removal and/or installation labor, loss of vehicles use, loss of time, inconvenience or any other consequential expense. ProParts, LLC disclaims any liability for consequential

damage due to breach of any written or implied warranty on all products manufactured by ProParts, LLC. The purchaser or user of any products distributed, sold or manufactured by ProParts, LLC assumes all risk related to and/or arising from the ownership or use of said product and agrees to indemnify and hold ProParts, LLC harmless from any and all claims brought by any person or entity against ProParts, LLC related to and/or arising from ownership and/or use of said product. Return goods authorization: Warranty returns will only be accepted by ProParts, LLC when accompanied by a valid return good authorization (rga) number. Product must be received by ProParts, LLC within 30 days of the date the rga is issued. Before a rga can be issued, the installer or end user must contact ProParts, LLC's technical department to discuss the problem. Any out of warranty ProParts, LLC products can be returned for repair. There is a minimum charge of \$50.00 for inspection and diagnosis. ProParts, LLC will provide an estimate of repairs and receive written authorization before repairs are made to the product.

Programming Instructions for : 2" Speedometer

SPEK™ MONITOR AND CONTROL PERFORMANCE GAUGE SPEEDOMETER

Refer to the "Flow Chart Programming Instructions" while reviewing this guide.

Gauge is field programmable by the operator while installed in the vehicle. This programming is accessed by pressing the control buttons located on the face or the meter dial, ONE AT A TIME. The "Down" and "Up" buttons move the pointer to a desired setting or controls the faceplate illumination. Gauge is field programmable by the operator while installed in the vehicle. This programming is accessed by pressing the control buttons located on the face or the meter dial, **ONE AT A TIME**. The "Down" and "Up" buttons move the pointer to a desired setting or controls the faceplate illumination.

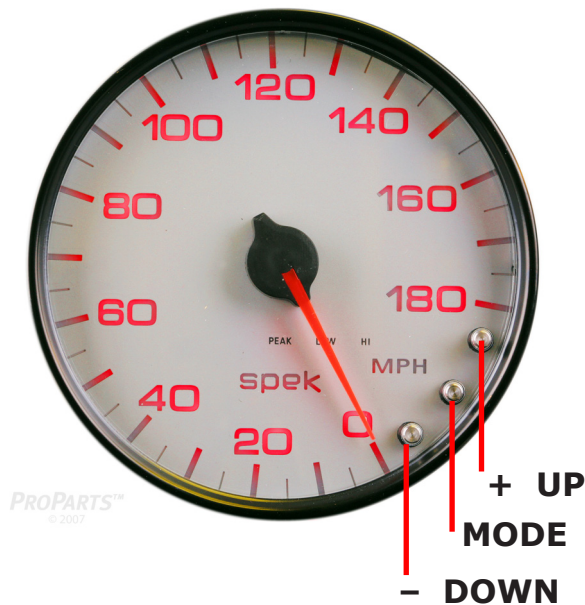

MAIN MENU	SUBMENU
NORMAL/DIAL BRIGHTNESS	OPTION LEARN SPEED BY MILE POSTS
PEAK PLAYBACK	OPTION:RESTORE FACTORY DEFAULT
HIGH RED-LINE SETTING	OPTION CALIBRATE GAUGE BY SPEED
LOW THRESHOLD SETTING	
COLOR SCHEME	OPTION A:DEMO MODE
DIAL BRIGHTNESS	OPTION: POINTER BRIGHTNESS

U.S.Patent # 7,612,660 and # 7,278,749 Additional Patents Pending

Programming Instructions for : 2" Speedometer

PROGRAMMING STARTS IN MAIN MENU

PRESS PROGRAM BUTTON ONE (1) AT A TIME IN THE MAIN MENU MODE.

1 NORMAL OPERATION:

On power up, the meter usually starts operation in **NORMAL OPERATION**. Gauge reads the sensor value as temperature, pressure, etc. The "Down" and "Up" buttons will control the brightness of the dial lighting. Press the center "Mode" button to save the setting and advance you to **2 PEAK PLAYBACK**

2 PEAK PLAYBACK:

Reads the highest value displayed on the meter since the last time the "Peak" value was displayed. Pressing the "Down" or "Up" control button will control the gauge dial illumination. Press the center "Mode" button to advance to **3 HIGH RED-LINE SETTING**

3 HIGH RED-LINE SETTING:

Sets the point at which "HIGH" warning threshold is reached for that specific gauge. The "Down" and "Up" buttons will move the dial pointer to select "Maximum Threshold". During normal operation the gauge constantly monitors the sensor value and compares it to the "HIGH" threshold. If the threshold is exceeded, the red "HI" indicator is turned on and an output signal generated. Press the center "Mode" button to save the setting and advance to **4 LOW THRESHOLD SETTING**

4 LOW THRESHOLD SETTING:

Set the Minimum Threshold: Sets the point at which "LOW" warning threshold is reached for that specific gauge. The "Down" and "Up" buttons will move the dial pointer to select the **LOW THRESHOLD SETTING**. During normal operation the gauge constantly monitors the sensor value and compares it to the "LOW" threshold. If the sensor value drops below the threshold, the yellow "LOW" indicator is turned on and an output signal generated. Press the center "Mode" button save the setting and advance to **5 COLOR SCHEME**

5 COLOR SCHEME:

Set Faceplate Color Scheme: Operator can select the color of the gauge dial illumination. Each time you press the "Down" control button you scroll through dial color selection until the dial light goes off. Then press the "Up" button to reverse the scroll. Select your dial color illumination by pressing the center "Mode" button to save the setting and return to **NORMAL OPERATION**

6 DIAL BRIGHTNESS:

Adjust the dial brightness for day or evening driving conditions The RIGHT and LEFT command buttons will dim or brighten the faceplate illumination. Press the center "Mode" button to save the setting and advance you to **NORMAL OPERATION**

Programming Instructions for : 2" Speedometer

SUBMENU

SUBMENU IS ACCESSED THROUGH THE MAIN MENU. FIRST GO TO THE APPROPRIATE LEVEL OF THE MAIN MENU AND THEN FOLLOW THE INSTRUCTIONS IN THE PROGRAMMING FLOW DIAGRAM TO ENTER THE SUBMENU. PRESS THE "MODE" AND "UP" OR "MODE" AND "DOWN" BUTTONS SIMULTANEOUSLY FOR 5 SECONDS TO ENTER THE SUBMENU AND ONE BUTTON AT A TIME WHILE IN THAT SUBMENU.

SPEK™ PERFORMANCE SPEEDOMETER GAUGE: THIS GAUGE USES MICROPROCESSOR TECHNOLOGY FOR MEASURING SPEED AND DISTANCE. IT CAN BE USED IN ORIGINAL EQUIPMENT MANUFACTURERS APPLICATIONS AS WELL AS IN AFTERMARKET INSTALLATIONS. SPEK™ SPEEDOMETER DEFAULT SIGNAL IS 1000 PULSES AT 60 MPH. ANY OTHER SIGNAL MUST BE LEARNED BY THE GAUGE. THE PREFERRED METHOD IS LEARN BY MILEPOST. AN ALTERNATIVE METHOD IS LEARN BY SPEED. BOTH ARE DEFINED BELOW

OPTION: LEARN SPEED BY MILEPOSTS: Proceed to a race shop with a dynamometer or a race track. Contact the authority to locate a measured mile. Follow the calibration instructions on the flow chart. An Alternative method is described under **Option: Calibrate gauge by speed**

OPTION: CALIBRATE GAUGE BY SPEED: This is an alternative method to learn speed by mile posts. Proceed to a race shop with a dynamometer or racetrack. Follow the directions on the flow chart.

OPTION:RESTORE FACTORY DEFAULT: Activation of the Default will erase all field calibration setup settings that are programmed. Factory calibrations will not be affected.

OPTION :DEMO MODE: Displays the features of the meter. The pointer goes up and down the scale, the dial colors change and the **HI**, **LOW** and **PEAK** warning indicators light. The Demo mode does not time out. If the gauge is turned off in the Demo mode, it will start up in the Demo Mode. Press the "Mode" button to return the gauge to **NORMAL OPERATION**.

OPTION: POINTER BRIGHTNESS MODE: The "Down" and "Up" buttons adjust the dial pointer brightness to blend in with original manufacturer's gauges and the owner's requirements Press the center MODE button to save the setting and return to **NORMAL OPERATION**

Programming Instructions for : 2" SPEEDOMETER

GAUGE CRITICAL CONDITION

GAUGE TYPE	ALERT FLASHES "RED"
TEMPERATURE	HIGH
PRESSURE	LOW
TACHOMETER	HIGH
PYROMETER	HIGH
NITROUS OXIDE PRESSURE	LOW
BOOST PRESSURE	HIGH
AIR/FUEL	LOW
VOLTMETER	LOW

ALERT/

OUTPUT GUIDE

PROGRAMMING INFORMATION:

- TO RESET THE PROGRAM TO NORMAL OPERATION FROM ANY MODE PRESS THE "UP" AND "DOWN" BUTTONS SIMULTANEOUSLY. THIS SOFT RESET CANCELS THE INFORMATION YOU PROGRAMMED IN THAT MODE ONLY AND RETURN YOU TO NORMAL OPERATION.
- THE FACEPLATE WILL "FLASH" WHEN BUTTONS ARE DEPRESSED TO ACKNOWLEDGE COMMANDS.
- PROGRAMMING ERRORS WILL BE SIGNALLED BY FLASHING THE FACEPLATE LIGHTING "PURPLE", "BLUE", "GREEN" THEN "ORANGE".
- IF PROGRAMMING IS INACTIVE FOR 120 SECONDS THE MODE WILL TIME OUT AND THE GAUGE WILL RETURN TO NORMAL OPERATION, EXCEPT FOR THE DEMO MODE. THE DEMO MODE WILL NOT TIME OUT UNTIL THE CENTER MODE BUTTON IS DEPRESSED. IF THE GAUGE IS TURNED OFF IN THE DEMO MODE IT WILL START UP IN THE DEMO MODE.
- TO RESTORE FACTORY DEFAULTS, PRESS THE "MODE" BUTTON ONCE TO ENTER THE **PEAK PLAYBACK**. THEN PRESS AND HOLD THE "MODE" AND "UP" BUTTONS FOR FIVE SECONDS. YOUR PROGRAMMING WILL BE ERASED BUT FACTORY PROGRAM WILL NOT BE AFFECTED.

U.S. Patent # 7,612,660
U.S. Patent # 7,278,749
Additional Patents Pending

Wiring Installation Instructions for : 2" Speedometer

SPEK™ MONITOR AND CONTROL PERFORMANCE GAUGE SPEEDOMETER

PACKAGE CONTAINS:

- Speedometer Gauge 2"
- Wiring Harness
- Mounting Cup (Not required for pod installation)
- (2) Neoprene EDPM Grommets

FEATURES:

SPEEDOMETER FEATURES:

- OPTIONAL 40 AMP OUTPUT CONTROL RELAY AND OUTPUT RELAY CABLE (PART # 14820) SOLD SEPARATELY
- GAUGES ARE PROGRAMMED THROUGH WATER RESISTANT STAINLESS STEEL SEALED COMMAND KEYS LOCATED ON THE FACEPLATE. NO CONTROL BOXES OR HAND HELD REMOTE CONTROL NEEDED.
- FIVE (5") INCH SPEEDOMETER IS DESIGNED WITH A 2 1/16, 52MM CUP. THE GAUGE ATTACHES TO GAUGE MOUNTING BRACKET (PART # 81105) FOR EASY PILLAR POD MOUNTING. NO NEED TO DRILL HOLES IN YOUR DASH.

INSTALLATION INSTRUCTIONS:

- 1** DISCONNECT NEGATIVE (-) BATTERY TERMINAL.
 - 2** VARIOUS MOUNTING SOLUTIONS ARE PRESENTED BY PROPARTS, LLC ON THEIR WEBSITE AT www.ProPartsLLc.com
- DASH INSTALLATION:** SELECT LOCATION IN THE DASH TO MOUNT GAUGE AND CUT A 2 1/16" HOLE. USE A FILE TO INCREASE THE HOLE SIZE IF REQUIRED. BE SURE THERE IS SUFFICIENT ROOM BEHIND THE HOLE FOR THE METER CASE AND THE CONNECTORS YOU WILL USE.
- 3** IF A SUITABLE HOLE IN THE FIRE WALL IS NOT AVAILABLE, CUT AN 11/16 HOLE.
 - 4** TWO GROMMETS MUST BE CUT TO PERMIT INSTALLATION OF WIRING HARNESS. (**SEE DIAGRAM 2**)

Wiring Installation Instructions for : 2" Speedometer

- 5** INSTALL THE TWO (2) GROMMETS AND MOUNTING CUP ON THE WIRING HARNESS AS SHOWN IN **DIAGRAM 1**. ONE GROMMET IS FOR THE HOLE IN THE FIREWALL AND THE SECOND IS FOR THE BACK OF THE GAUGE MOUNTING CUP.
- 6** DO NOT CONNECT WIRING HARNESS TO THE GAUGE UNTIL THE OTHER CONNECTIONS HAVE BEEN MADE AND TESTED.
- 7** CONNECT THE **RED** (+ 12 VOLT SUPPLY) WIRE TO "ON" CIRCUITS THAT GET POWER WHEN THE IGNITION IS TURNED-ON. THIS CIRCUIT MUST BE FUSED BEFORE THE IGNITION SWITCH (1 AMP, 3AG FAST ACTING LITTLEFUSE® #312001 OR EQUIVALENT).
- 8** CONNECT THE SIGNAL WIRE TO THE ELECTRIC SPEED SENSOR
- 9** CONNECT THE **BLACK** WIRE TO A GOOD GROUNDING POINT ON THE CAR'S CHASSIS.
- 10** CONNECT THE **WHITE** WIRE TO THE DIMMER VOLTAGE GOING TO THE DASH LIGHTS. THIS WILL CAUSE THE METER BRIGHTNESS TO TRACK THE BRIGHTNESS OF THE REST OF THE INDICATORS.
- 11** CONNECT THE APPROPRIATE SENSOR SIGNAL AND GROUND WIRES AND LEAVE ALL OTHER WIRES UNCONNECTED.
- 13** PLUG THE WIRING HARNESSES INTO THE GAUGE AND MOUNT IN POD OR DASH.
- 14** FOR DASH MOUNTING, ATTACH MOUNTING CUP OVER THE BACK OF THE GAUGE AND HAND TIGHTEN. DO NOT OVER-TIGHTEN. MOUNT CUP BEFORE INSTALLING GROMMET. FAILURE TO DO SO WILL TWIST WIRES CAUSING A SHORT CIRCUIT.
- 15** POWER UP THE GAUGE AND INSPECT ALL CONNECTIONS. IF GAUGE IS OPERATING NORMALLY, PROCEED TO "PROGRAMMING MANUAL".

Wiring Installation Instructions for : 2" Speedometer

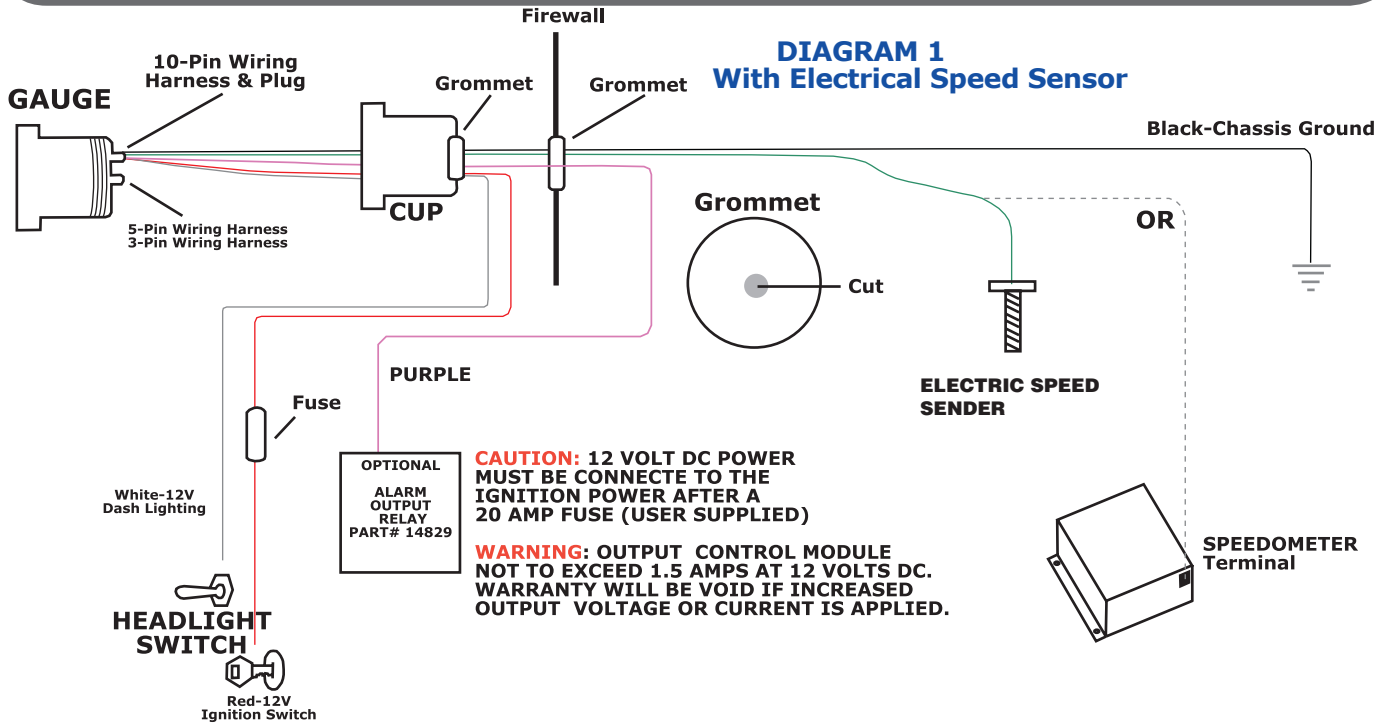

**PATENTED WIDE ANGLE DIAL FOR SUPERIOR VISIBILITY
U.S PATENT #7,278,749**

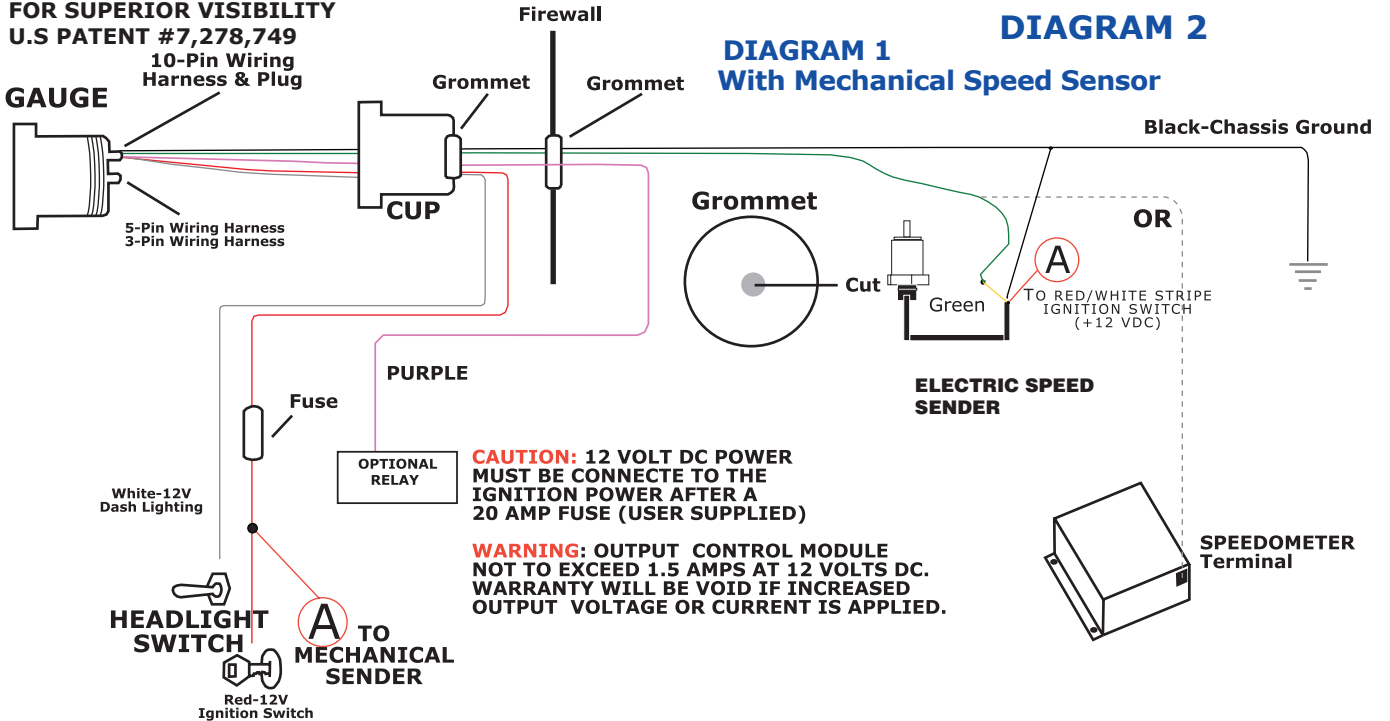

**PATENTED WIDE ANGLE DIAL FOR SUPERIOR VISIBILITY
U.S PATENT #7,278,749**

Wiring Installation Instructions for : 2" Speedometer

DIAGRAM 2

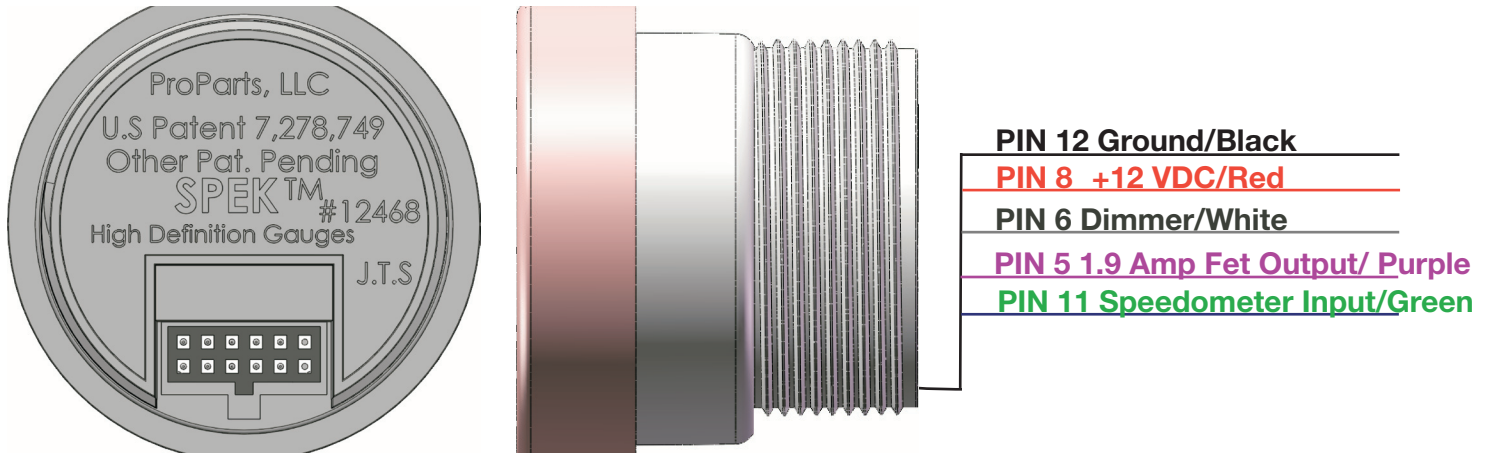

1	2	3	4	5	6
7	8	9	10	11	12

Wiring Installation Instructions for : 2" Speedometer

THERE ARE THREE SECTIONS TO THIS MANUAL: WIRING INSTRUCTIONS, PROGRAMMING INSTRUCTIONS AND FLOW CHART PROGRAMMING INSTRUCTIONS. PLEASE READ EACH SECTION CAREFULLY BEFORE ATTEMPTING TO INSTALL OR OPERATE THIS PRODUCT.

WARNING:

- **ALL INSTRUCTIONS IN THIS MANUAL MUST BE FOLLOWED TO INSURE SAFE INSTALLATION AND OPERATION OF THIS PRODUCT.**
- **NEVER DISASSEMBLE MODIFY OR TAMPER WITH THIS PRODUCT. THIS COULD CAUSE DAMAGE AND MAKE THEM UNSAFE TO USE. TAMPERING WITH THE PRODUCT WILL VOID THE LIMITED WARRANTY.**
- Σ **INSTALLATION MUST BE PERFORMED BY AN EXPERIENCED AUTOMOTIVE TECHNICIAN.**
- **INSTALLER MUST USE SAFETY GLASSES.**
- **DISCONNECT THE NEGATIVE BATTERY TERMINAL BEFORE BEGINNING INSTALLATION. PROPARTS LLC IS NOT RESPONSIBLE FOR DAMAGE TO ENGINE, VEHICLE OR UNIT CAUSED BY ELECTRICAL SHORTS.**
- **DURING INSTALLATION, DO NOT INTERFERE WITH ANY EXISTING CONNECTIONS OR WIRES.**
- **ALL ELECTRICAL CONNECTIONS USE SOLDER LESS CONNECTORS AND INSULATE ALL CONNECTIONS WITH ELECTRICAL TAPE.**
- **AVOID WIRING NEAR ENGINE, EXHAUST SYSTEM, TURBINE OR ANY AREA THAT MAY RESULT IN DAMAGE.**
- **DISCONTINUE USE OF THE PRODUCT IF SMOKE OR A STRANGE ODOR IS PRESENT.**

CAUTION

- **PROPARTS LLC IS NOT RESPONSIBLE FOR INCORRECT INSTALLATION OR PROGRAMMING OF SPEK™ GAUGES OR CONTROLLERS.**
- **SPEK™ GAUGES AND CONTROLLERS ARE DESIGNED FOR 12V DC ELECTRICAL SYSTEMS WITH A NEGATIVE GROUND.**
- **DO NOT ADJUST THE GAUGES OR GAUGE PROGRAM WHILE DRIVING**
- **OBEY ALL RULES AND REGULATIONS OF HIGHWAY AND STREET DRIVING.**
- **INSTALL SENSOR AND WIRE AWAY FROM HIGH HEAT AND / OR VIBRATION AREAS.**
- **USE CARE WHEN CONNECTING OR DISCONNECTING THE WIRING HARNESS. PULL OUT EACH CONNECTOR WHILE PRESSING THE LOCK OF THE CONNECTOR FIRMLY.**
- **IF THE BATTERY TERMINAL IS DISCONNECTED, THE AUDIO, CLOCK AND OTHER MEMORY DATA MAY BE LOST. THE NECESSARY DATA WILL HAVE TO BE RESET AFTER INSTALLATION.**

Wiring Installation Instructions for : 2" Speedometer

12 MONTH LIMITED WARRANTY

Spek-Pro/Auto Meter Products, Inc. warrants to the consumer that all Auto Meter High Performance products will be free from defects in material and workmanship for a period of twelve (12) months from date of the original purchase. Products that fail within this 12 month warranty period will be repaired or replaced at Auto Meter's option to the consumer, when it is determined by Spek-Pro/Auto Meter Products, Inc. that the product failed due to defects in material or workmanship. This warranty is limited to the repair or replacement of parts in the Spek-Pro/Auto Meter Instruments. In no event shall this warranty exceed the original purchase price of the Auto Meter instruments nor shall Spek-Pro/Auto Meter Products, Inc. be responsible for special, incidental or consequential damages or costs incurred due to the failure of this product. Warranty claims to Spek-Pro/Auto Meter must be transportation prepaid and accompanied with dated proof of purchase. This warranty applies only to the original purchaser of product and is non-transferable. All implied warranties shall be limited in duration to the said 12 month warranty period. Breaking the instrument seal, improper use or installation, accident, water damage, abuse, unauthorized repairs or alterations voids this warranty. Spek-Pro/Auto Meter Products, Inc. disclaims any liability for consequential damages due to breach of any written or implied warranty on all products manufactured by Auto Meter.